

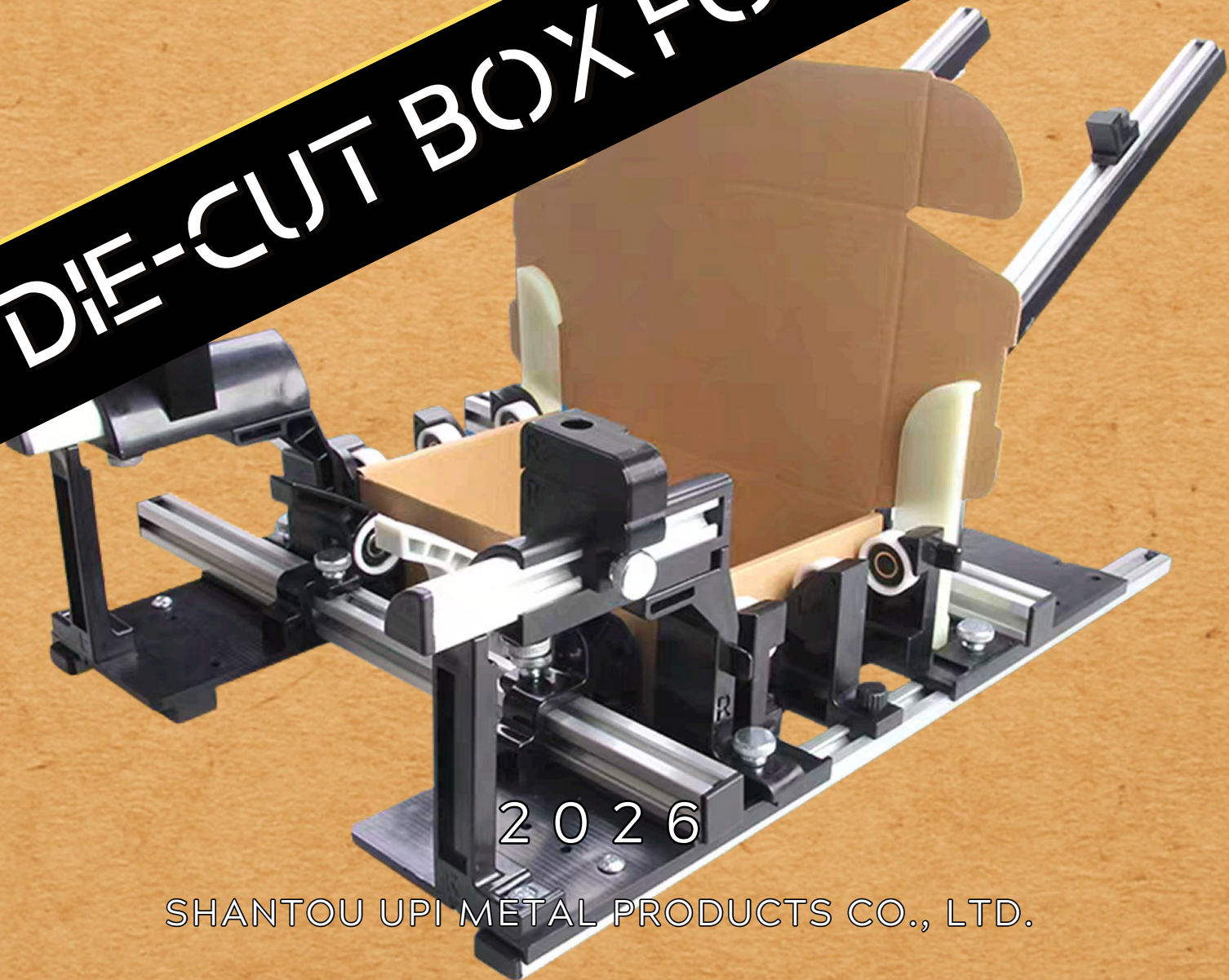

# METAL PRODUCTS

# DIE-CUT BOX FOLDING JIG



2026

SHANTOU UPI METAL PRODUCTS CO., LTD.

Thank you very much for purchasing our die-cut box folding fixture. This equipment is only compatible with this specific type of die-cut box cardboard design.

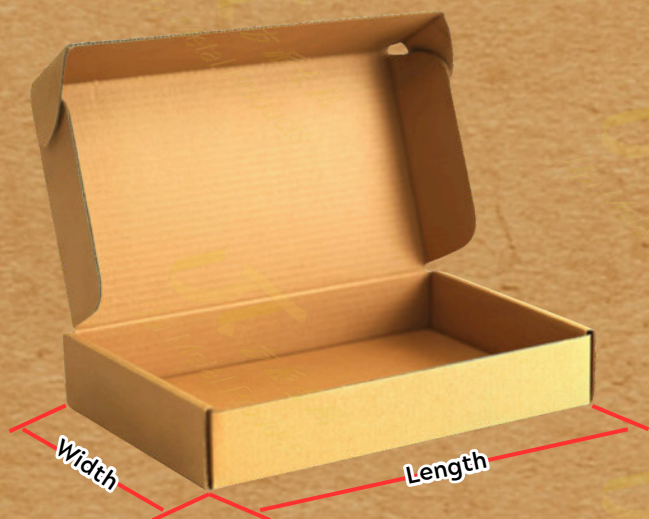
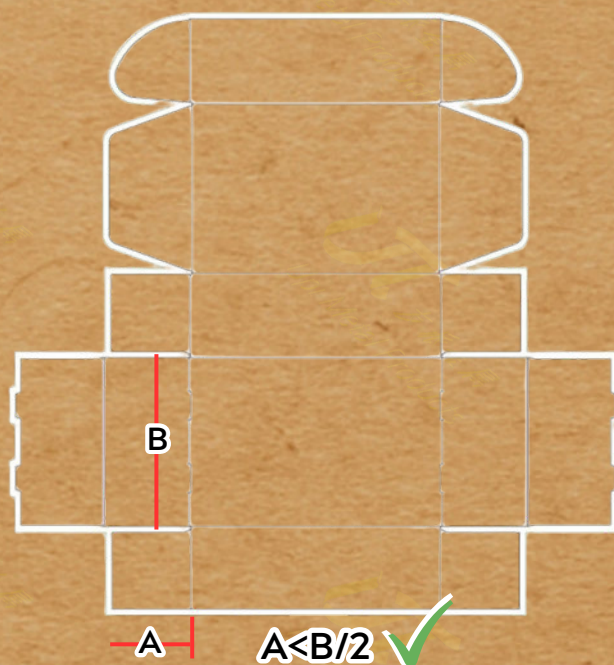

### Fixture Specification Sheet

Length	Width
≤65CM	≤65CM
≤55CM	≤55CM
≤45CM	≤45CM
≤35CM	≤35CM
≤25CM	≤25CM
≤15CM	≤15CM

Our jig can fold die-cut boxes with a maximum folded size of 65×65 cm. As oversized jigs take up more workbench space, we offer jigs in different sizes. You can select the appropriate model from the table based on the maximum size of your boxes (Length and Width can be combined freely). Each jig model is adjustable and compatible with smaller die-cut boxes, with a minimum folded size of L10 × W5 × H2 cm.

# Accessories List



**Left-right assembly set (1 pair)**

**Left-right parts (1 pair)**

**(Nuts Included) × 2**



## Jig Spec & Support Qty Comparison

Length	F	B	Width	L/R
≤65CM	x 6	x 6	≤65CM	x 12
≤55CM	x 5	x 5	≤55CM	x 10
≤45CM	x 4	x 4	≤45CM	x 8
≤35CM	x 3	x 3	≤35CM	x 6
≤25CM	x 2	x 2	≤25CM	x 4
≤15CM	x 1	x 1	≤15CM	x 2

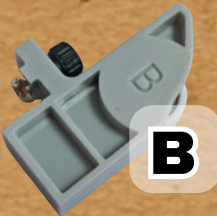

**Left-right parts (1 pair)**

# 1. Assemble the jig

1. First, loosen the two hand screws ① and ②. Insert the two aluminum profile rods ③ and ④ into the main frame ⑥ along the sliding grooves (note: keep the four sliding block nuts ⑤ facing upwards).

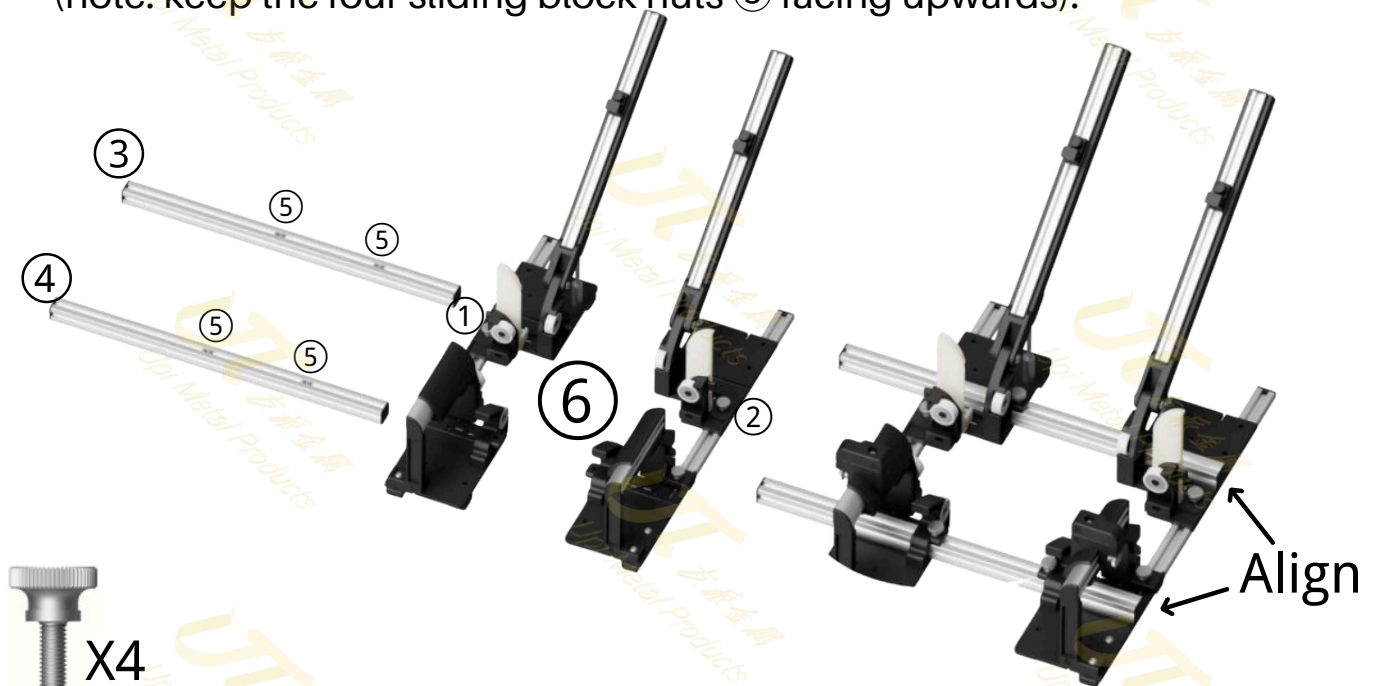

2. As shown in the figure, align the ends of aluminum profile rods ③ and ④ with the main frame ⑥. Then push the four sliding block nuts ⑤ inside the aluminum profiles to the positions directly below the screw holes, and finally tighten the four thumb screws.

3. Prepare two hand screws and a pair of positioning blocks (note: the positioning blocks are divided into left and right, marked with L and R respectively).

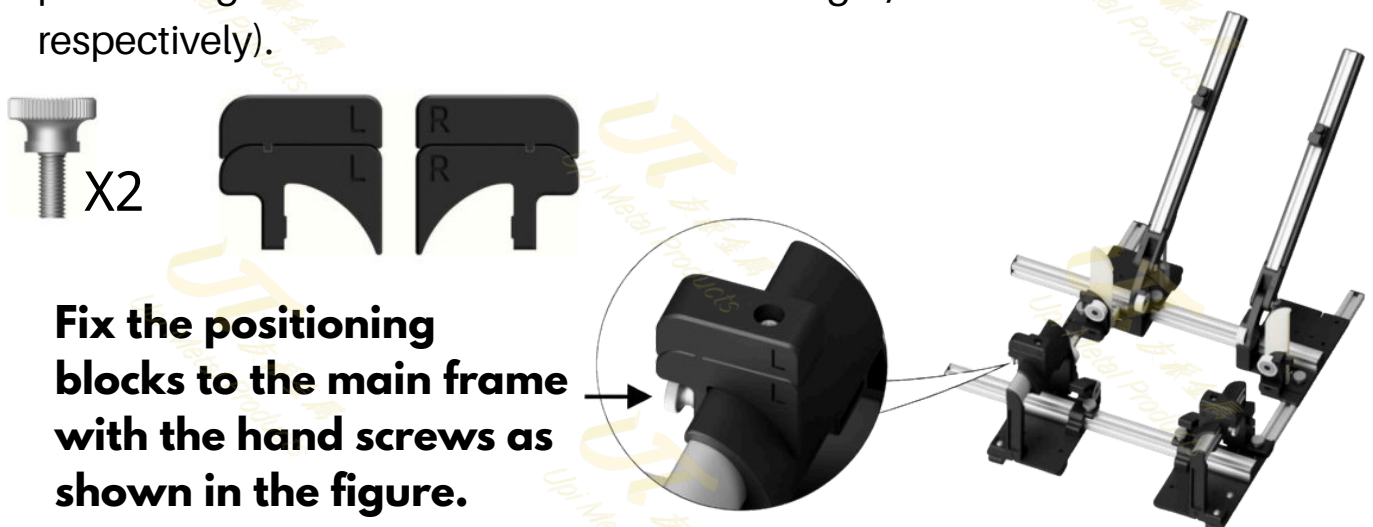

**Fix the positioning blocks to the main frame with the hand screws as shown in the figure.**

## 2. Dimensional adjustment

1. Loosen the four hand screws ①, ②, ③ and ④ shown in the right figure. Adjust the jig to a larger size in the direction indicated by the arrows.

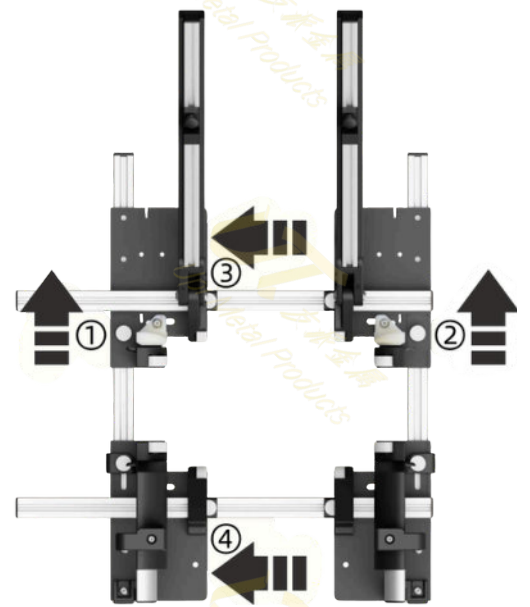

2. Place the pre-folded die-cut box into the jig according to the "Correct" diagram in the left figure, and avoid the two "Incorrect" diagrams shown below.

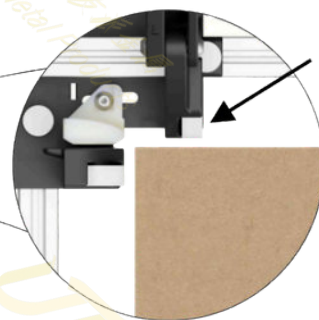
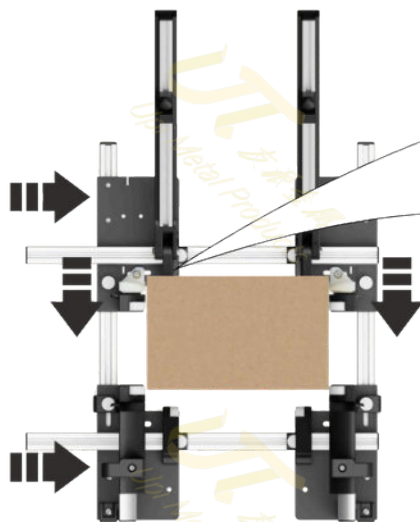
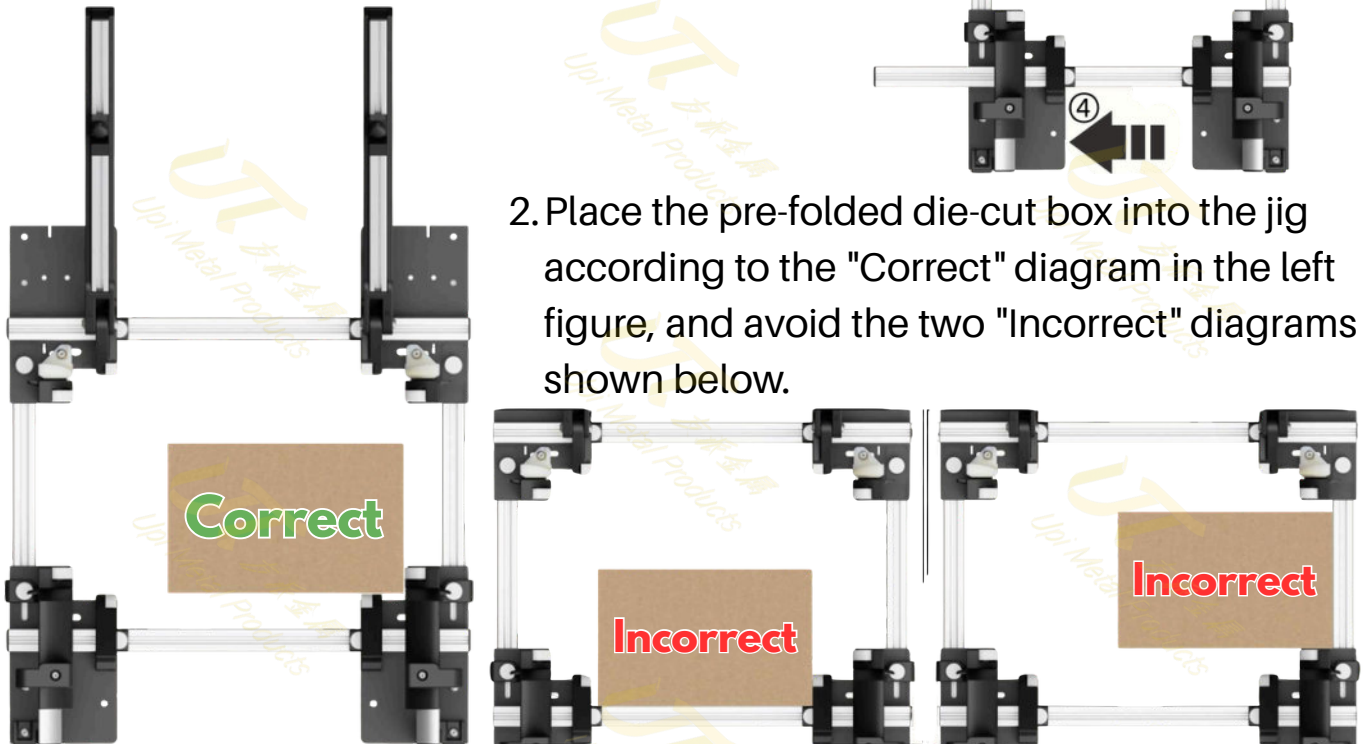

**Bending  
guide wheel**

3. Push the jig toward the pre-folded die-cut box as indicated by the arrows in the figure. (Note: A gap of approximately 2 mm should be reserved between the 8 bending guide wheels and the surface of the pre-folded die-cut box they will contact; do not clamp it too tightly!) Finally, tighten the four thumb screws.

### 3. Cardboard positioning

1. Prepare a flat die-cut box cardboard and fold the side flaps (as shown in the bottom-left diagram).
2. Loosen the hand screw of the positioning rod ① and the hand screw of the positioning block ②. If the height of the die-cut box is  $\geq 12$  cm, you also need to loosen the secondary telescopic hand screw ③.
3. Fit part ④ of the cardboard box to the measuring jaw ⑤, then move the positioning rod ① to fit the measuring jaw ⑥ to part ⑦ of the cardboard box.
4. Move the positioning block ② to make the white area of the positioning block fit the edge of the cardboard, and finally tighten the hand screws.

**The positioning way of this die-cut box folding jig works for most die-cut boxes.**

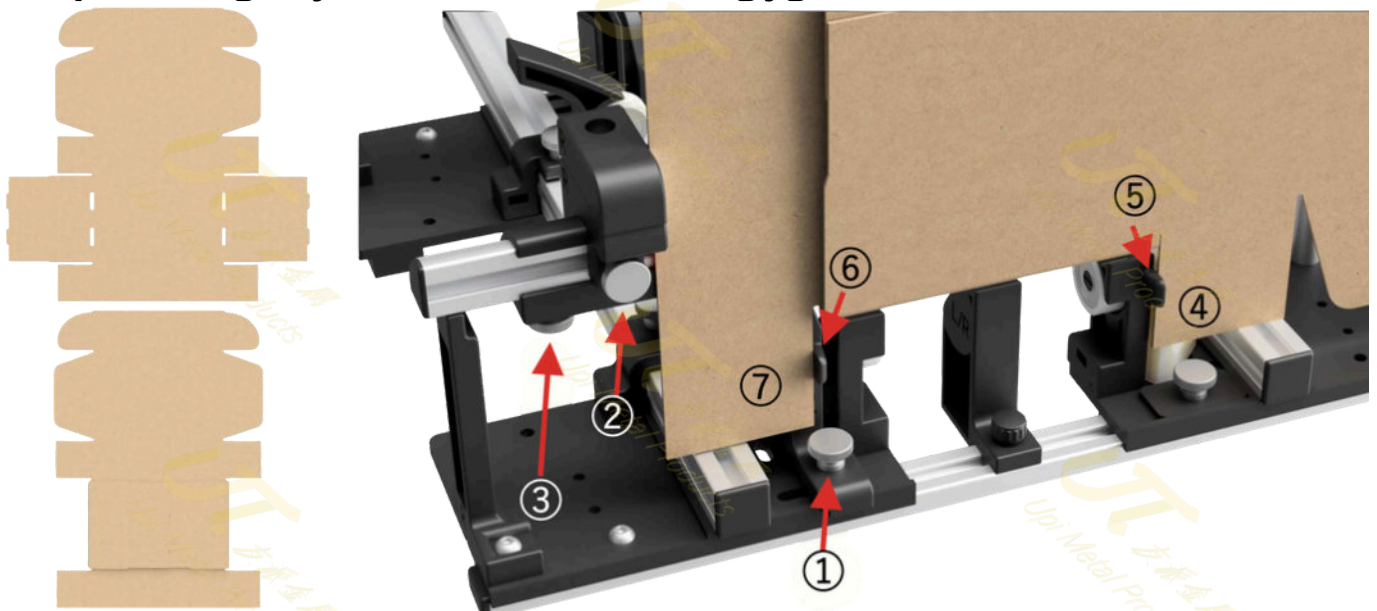

#### Box Cover Support Rod ① & Stop Block ②

1. As shown in Diagram 1, loosen the screw and pull the aluminum rod outward to extend the box cover support rod ① for supporting larger die-cut box covers.
2. As shown in Diagram 2, loosen the screw and adjust the stop block ② to press against the edge of the die-cut box cover, which resolves the issue of small die-cut boxes springing back when the box body is pressed down.

Note: The spring-back issue under pressure usually occurs with small die-cut boxes (due to rigid material and excessively shallow pre-folding creases). For larger-sized die-cut boxes, the stop block ② is not required to be installed.

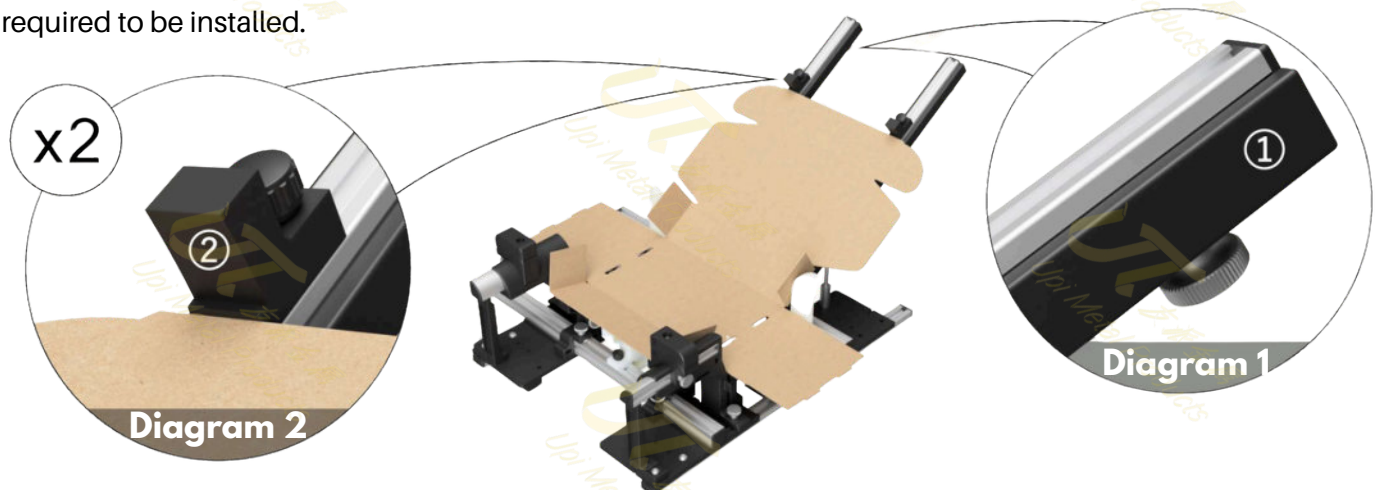

## 4. Add auxiliary support components

Take the die-cut box out of the jig. Install the front supports (F), rear supports (B), and left/right supports (L/R) as required.

Note: Pay attention to distinguishing the installation positions of the three types of supports.

**TIPS: On the premise that the bottom of the die-cut box does not collapse after being pressed down, install as few supports as possible.**

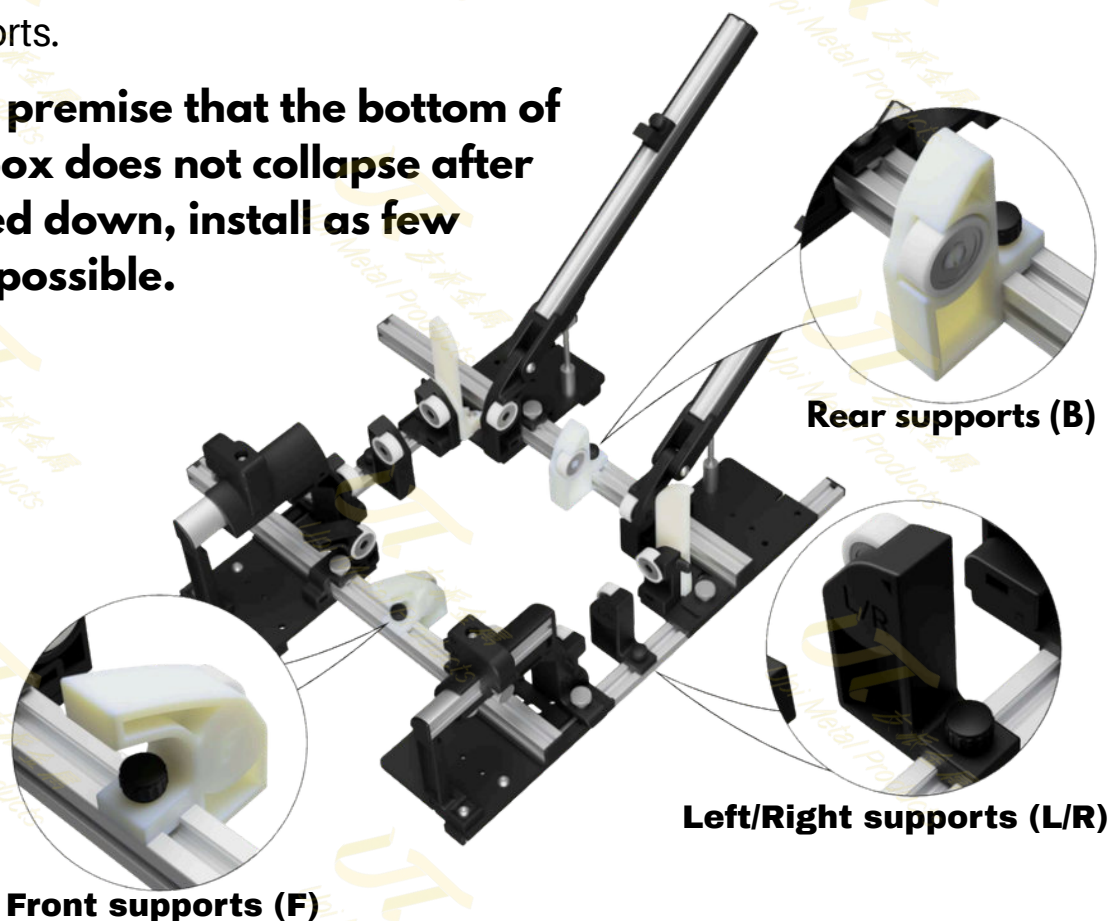

### Assembly Schematic of Supports and T-slot Nuts



# Standard Operating Procedures

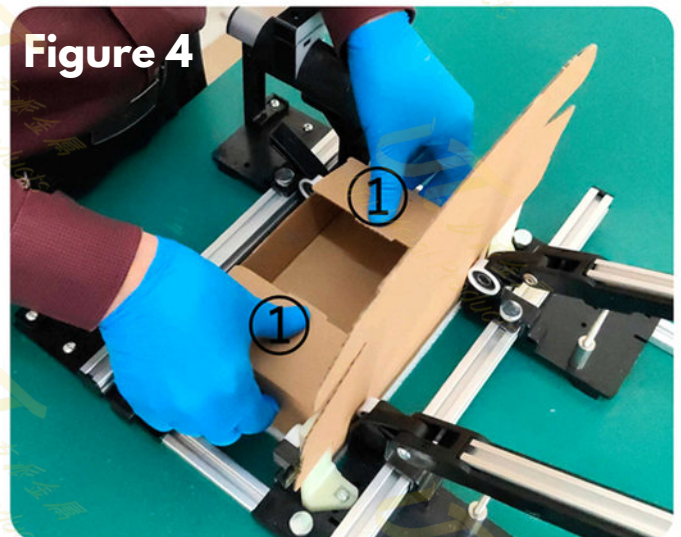
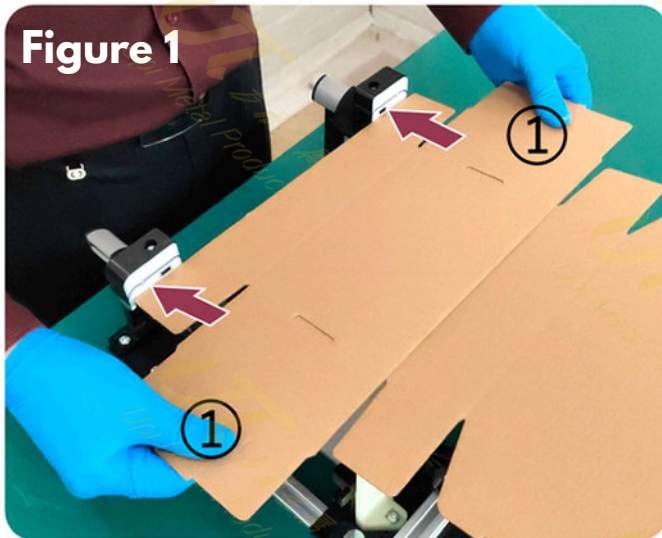

1. As shown in Figure 1, hold the side flaps ① of the die-cut box cardboard, align the edges tightly against the positioning blocks (refer to the arrow marks), and then pull the cardboard down until it reaches the state shown in Figure 2.
2. As shown in Figure 3, manually press the cardboard into the jig. While taking the box out, complete the folding of the side flaps ① (see Figure 4).

# Frequently Asked Questions & Solutions

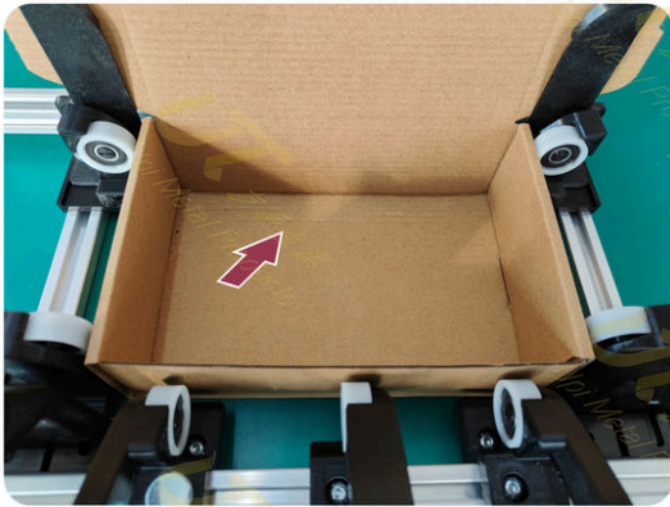

## Problem Description:

As indicated by the arrow in the left figure, after the die-cut box is pressed into the fixture, creases appear on the bottom of the box.

## Solutions:

1. When pressing down the cardboard, place your fingers as close as possible to the edges of the box bottom.
2. Appropriately increase the gap between the pulleys on the support and the folded box to reduce the resistance during box folding.

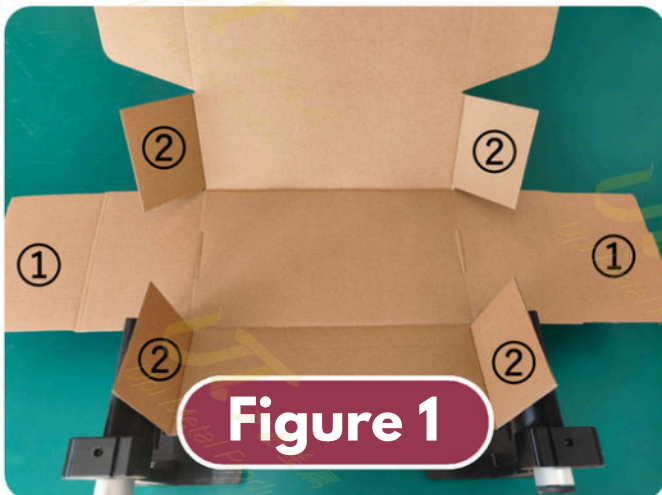

Figure 1

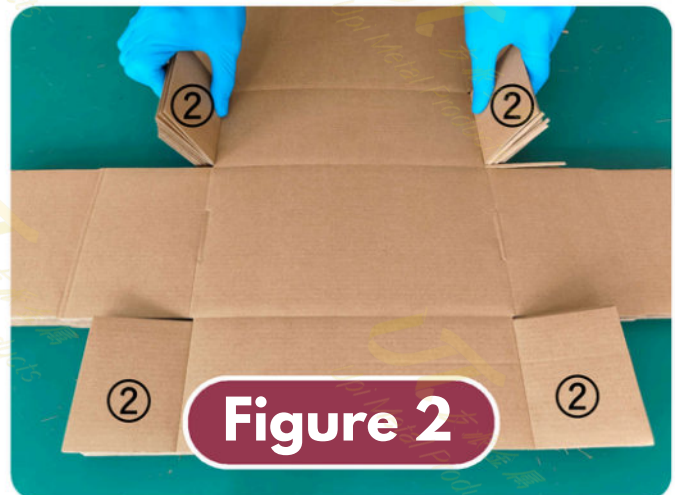

Figure 2

## Problem Description:

As shown in Figure 1, when the die-cut box is placed in the jig and you hold the side flaps ① of the die-cut box cardboard to pull it downward, the four folded corners ② will abut against the bottom surface, preventing the box from folding properly.

## Solution:

As shown in Figure 2, pre-fold the four folded corners ② in batches before using the jig.

# Spare Parts Usage Instructions

## Spare Part 1: Upgraded No.1 Rod (Thinner)



### Function 1

Ensures smoother box removal and higher folding efficiency. (The standard No.1 Rod is pre-installed on the main support, which is more suitable for first-time operators. After mastering the folding technique, you may replace it with the upgraded No.1 Rod to improve efficiency.)

### Function 2

Eliminates interference issues between the standard No.1 Rod and a small number of die-cut boxes with special dimensions that may hinder normal folding.

## Spare Part 2: Positioning Block Height Extension ①



The height extension ① can be removed by unscrewing the screws

This spare part is pre-assembled with the standard positioning block ② by default. For small-sized die-cut boxes (box width  $\leq 15$  cm), it is recommended to be removed; for boxes with a width  $> 15$  cm, it is recommended to be installed.

## Spare Part 3: EPE Foam

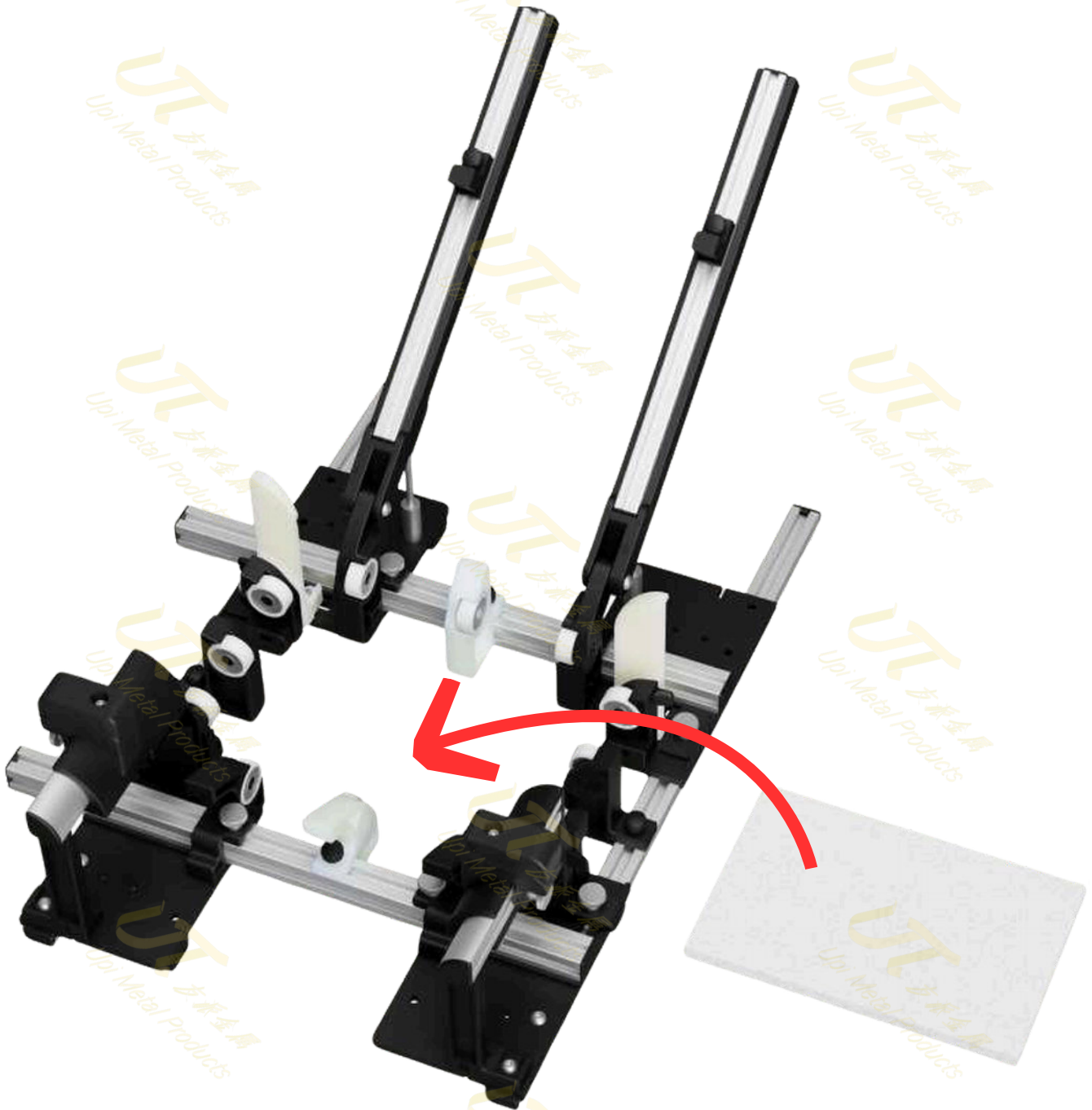

**Please cut the EPE foam to an appropriate size.**

1. If the box is relatively tall, you may either leave out the EPE foam or place it in the non-folding area of the jig to increase the depth of the box-folding area.
2. If the box is relatively short, place the EPE foam in the box-folding area of the jig.

# YOUR ONE-STOP OEM AND ODM SOLUTION FOR METAL PRODUCTS

At Upi, we bring years of experience in metal parts design and manufacturing to the table. Our expertise in metalworking and robust supply chain enable us to produce high-quality metal products for you, offering comprehensive OEM and ODM services. This brochure showcases a selection of our ODM products. For any specific needs, please contact us for more product information.



Shantou Upi Metal Products Co., Ltd.

**Mobile|WhatsApp|WeChat:** +86 15889258060

**Email:** Zach@upimetal.com

**Website:** <https://www.upimetal.com>

**Head Office | Production Site 1:** No.29 Anhua Road, Chenghua Street, Chenghai District, Shantou City, Guangdong Province, China

**Production Site 2:** No. 3, North Second Street, Xiangmang West Road, Dongguan City, Guangdong Province, China

